

Milli-Q®

Lab Water



# Milli-Q® HR 7000 Series High-throughput central purification systems

For volumes up to  
13,000 L/day

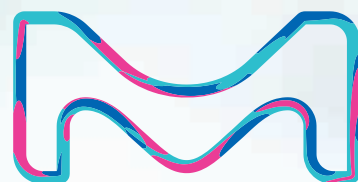

The life science business of Merck operates as  
MilliporeSigma in the U.S. and Canada.

**MERCK**

# YOUR total solution

from the people who know pure water best

Now more powerful and versatile than ever. We've redesigned our RiOs high-throughput central system to give you the **CAPACITY, CONFIGURATION** and **CONNECTIVITY** that today's lab facility needs to run smoothly.

## The new Milli-Q® HR 7000 is at the heart of any total pure water solution

The Milli-Q® HR 7000 system provides a high-throughput standard water purification solution that can reliably meet the diverse needs for Type 3 pure water – for a single laboratory or an entire research facility.

### Reliably feed all your pure water needs:

- **Taps** on benches
- **Systems and instruments**, including dishwashers, autoclaves, clinical analyzers, heating baths, humidity chambers, ice machines, and environmental chambers
- **Point-of-use polishers** and **purification systems** to obtain ultrapure water

### Achieve higher throughput than before:

With a constant flow rate of up to **220 L/h** (between 7°C and 30°C), the system has the capacity to purify up to several thousand liters per day of Type 3 pure water from tap water. Link up to 3 units to reach up to **13 000 L/day!**

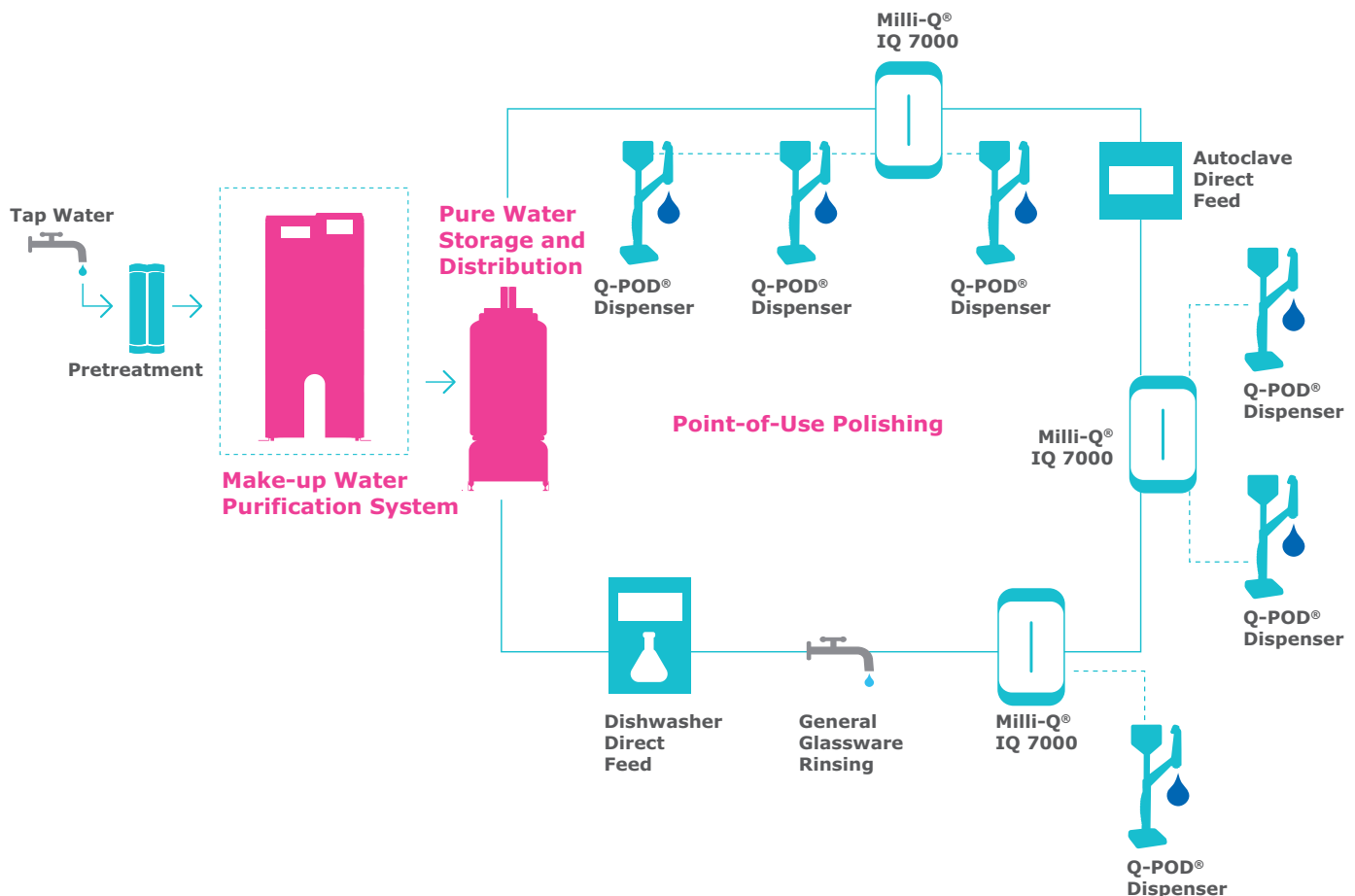

## Installation options that fit almost any configuration

The Milli-Q® HR 7000 system can be adapted to most laboratory or building configurations. It is capable of driving and controlling all ancillary equipment needed for a complete installation, including:

- Distribution pumps, single and duplex
- Reporting alarms from the pumps
- UV lamp in the distribution loop
- ASM (automatic sanitization module)
- Tank levels and alarms
- Consumable management (vent and final filters)
- 2 alarm outputs for connecting to a general BMS, LIMS or alarm, and 2 signals 4-20mA are available for monitoring
- Embedded web server technology compatible with LIMS and BMS via TCP/IP protocol
- Water detector to stop the water supply in case of a leak (option)
- Distribution loop TOC monitoring (option)
- Distribution loop Resistivity monitoring (option)

### Plug 'n' play compatibility with our SDS 500 storage, protection and distribution system

Easily connect Milli-Q® HR 7000 and SDS 500 systems for a **compact** and **clean** solution. This perfect pairing yields high storage and distribution flow possibilities.



### Trust in Pure Experience

For 50 years, Merck has been the partner of choice for water purification systems and services for lab scientists who need to assure the quality and reliability of results.

Merck provides a comprehensive range of water purification systems to fit your needs, space, building configuration, and budget.

- Customized solutions
- Valuable advice
- Comprehensive maintenance
- Qualification programs
- Budget planning

**From conception, design and installation, through to engineering expertise and technical support services, Merck can work with you through any project for full peace of mind.**

# Peace of Mind

with state-of-the-art technology & best-in-class support

Complementary purification technologies yield reliably pure water, enhance sustainability, and reduce running costs, making your facility more **PRODUCTIVE**, **ENVIRONMENTALLY FRIENDLY** and **COST-EFFECTIVE**.

## Pretreatment is tailored to your feed water quality

### For standard water feeds:

- Progard® pretreatment cartridges remove particles (0.5 µm filter), free chlorine and colloids (activated carbon filter)
- An anti-scaling agent protects the reverse osmosis (RO) membrane in hard water areas
- Bactericidal carbon prevents bacterial growth

If your source water has a high fouling index and/or high chlorine levels, supplementary backwashing carbon filters and an ultrafiltration system can be added via an external holder.

## Advanced RO & patented ERA™ technologies yield constant flow rates while reducing water consumption

### Advanced RO removes:

- 95-99% of ions
- 99% of all dissolved organics (MW >200 Da), microorganisms and particles

**ERA™ (Evolutive Reject Adjustment) technology** takes into account feed water quality (conductivity, temperature, hardness, alkalinity, CO<sub>2</sub>) to automatically **optimize water recovery (between 45% and 75%)** and **reduce water consumption by up to 50%** compared to other RO systems of similar throughput.

- Achieve constant flow and water recovery rates, regardless of feed water temperature
- Eliminate manual valve adjustments due to temperature fluctuations
- Reduce maintenance time and the risk of human error
- Increase RO cartridge lifetime, reducing consumables waste
- Optimize your system's uptime and reliability

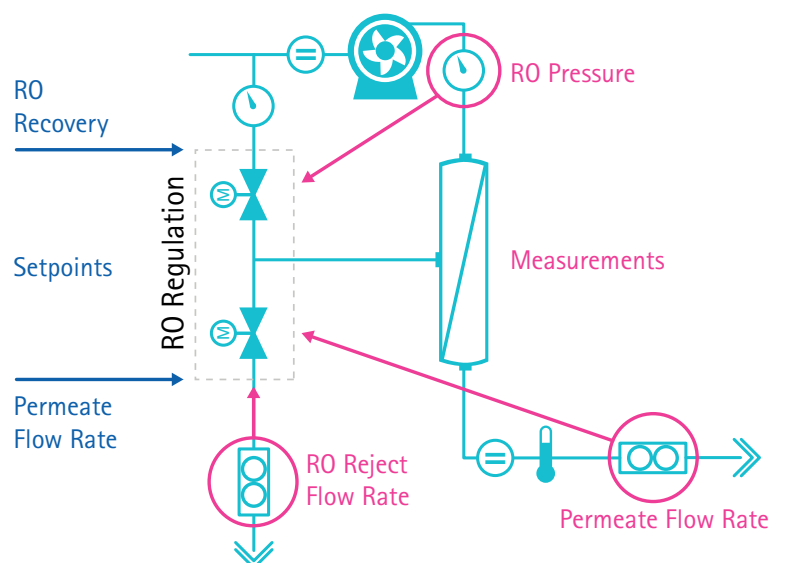

Our patented ERA™ technology saves you water, time and money.



**The Milli-Q® HR 7000 system is designed for quick and easy maintenance**

With its **ergonomic patented pack holder** and **helpful wizards** accessible from the touchscreen display, the new Milli-Q® HR 7000 system is quick and easy to maintain. Searching through user manuals for how to change a cartridge is no longer necessary; all instructions are at your fingertips, so you can get on with what's really important.

**At <50 dB, the system is as quiet as a conversation with someone next to you.**



**The unequalled quality of Milli-Q® services and support gives you total peace of mind throughout your system's lifetime**

At each stage of your project (conception, design and installation) to everyday use, Merck offers comprehensive, high quality support services that can be customized to meet your needs.

**Before installation**, a certified Field Service Engineer will analyze your feed water quality. During installation, the measured feed water parameters are then programmed into the Milli-Q® HR 7000 system memory, optimizing water recovery and maximizing system performance.

**Throughout the system's lifetime**, Merck offers service plans that can be tailored to meet your specific needs. Options range from a single annual preventive maintenance visit with replacement of aging parts, to full system coverage, including qualification, calibration, and verification services.

**Our certified Field Service Engineers can provide:**

- Operator training
- Technical and maintenance support
- Preventive maintenance and customized services, such as conductivity and temperature meter verification
- Assistance to help you successfully perform the Installation Qualification (IQ), Operational Qualification (OQ) and maintenance program within a cGMP and/or GLP environment

**Count on us to support your project with state-of-the-art technologies and manufacturing excellence.**

# connect to the heart

## of your Milli-Q® HR 7000 system

An interactive touchscreen and modern data management capabilities facilitate **MAINTENANCE, ACCESSIBILITY** and **DATA TRACEABILITY**.

The Milli-Q® HR 7000 series of systems are equipped with an integrated and powerful control panel. This user-friendly dashboard lets you easily navigate to access all main system data. In a few intuitive taps, you can view and control:

- System settings
- Production
- Storage levels
- Distribution
- Consumables status
- Preventive alarms and alerts

### Large, colored touchscreen display panel facilitates maintenance and control

<b>System status zone</b>	
Large display shows water qualities and distribution process	
Clear, visible status of all consumables	
<b>Notification zone for alerts and alarms</b>	

### No need to open a user manual to maintain the system – wizards guide you through basic maintenance

<p>If a consumable change is required, the system will display a yellow, blinking alert 15 days in advance. Just touch the yellow alert to open a new screen. A wizard will explain the maintenance procedure in easy, step-by-step instructions.</p>	
---	--

## Full connectivity assures lab productivity

### Authorized remote access, monitoring & control

Get peace of mind, prevent breakdowns and proactively ensure lab productivity with 24/7 remote access to your facility's central water system. Authorized users can now securely access the Milli-Q® HR 7000 system's functionality and data from anywhere—a network computer, or authorized laptops, tablets or smartphones.

- Ethernet connection to internet, LIMS or BMS
- Embedded web server generates real-time web pages to monitor system operations
- Trigger alerts or alarms in case of deviation from numerous adjustable set points
- Up to 3 users may access system at the same time



### Facilitate data management, improve traceability, and ease compliance

Easier access to your central water system and its data means better record-keeping and being more audit-ready.

- Up to 2 years of events are stored in the system and accessible via lab network or USB key
  - All running parameters are collected, including water quality, alarms and events, water usage, and consumables
- Generating automatic e-records to save time, money and paper
- Facilitate lab accreditation and re-accreditation processes (ISO 15189)

# Technical Appendix

## Milli-Q® HR 7000 series Type 3 Water Purification Systems

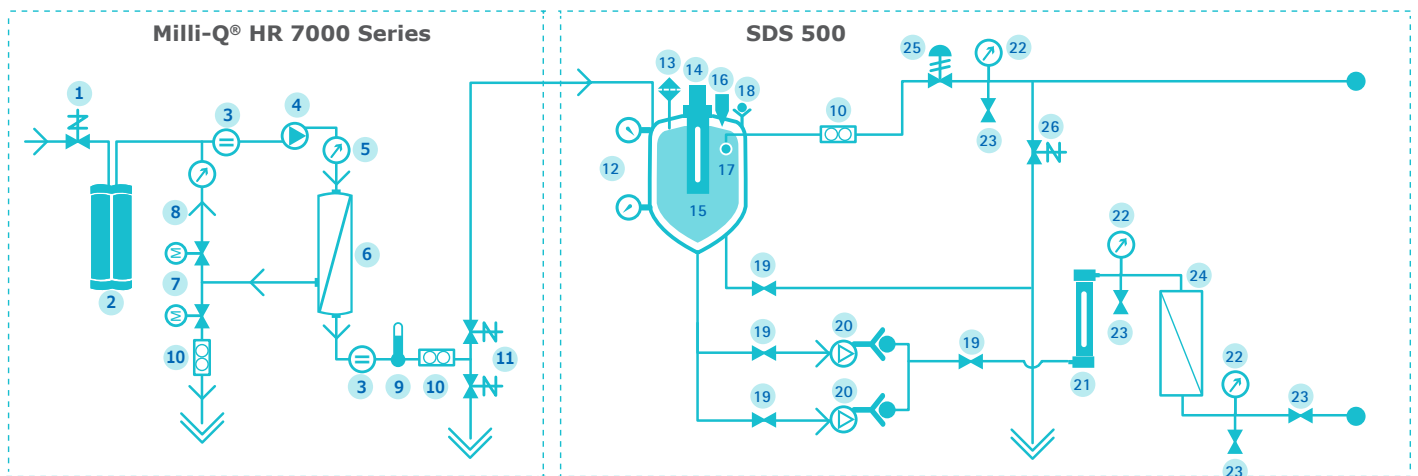

1. Inlet valve
2. Progard® pretreatment pack
3. Conductivity cell
4. RO pump
5. Pressure sensor
6. RO cartridge
7. Twin motorized valve - RO recirculation
8. RO circulation loop
9. Temperature sensor
10. Flow sensor
11. 3-way automatic rinsing valve
12. Tank level pressure sensors
13. Vent filter

14. Automatic Sanitation Module (ASM)  
(UV 254 nm; option instead of spray ball)
15. Tank
16. Overflow
17. Spray ball
18. Check valve
19. Valve
20. Distribution pump(s)
21. UV lamp (254 nm; option)
22. Pressure gauge
23. Sampling valve
24. Opticap® filter (0.22 µm)
25. Back pressure regulator
26. Automatic loop rinsing valve

## System Dimensions

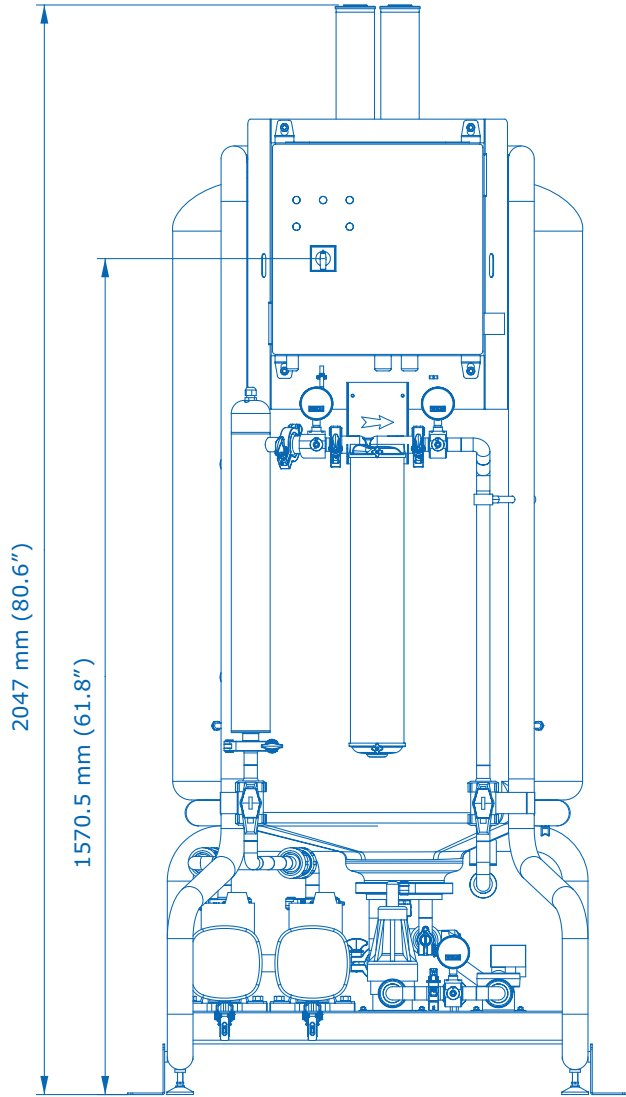

**SDS 500**

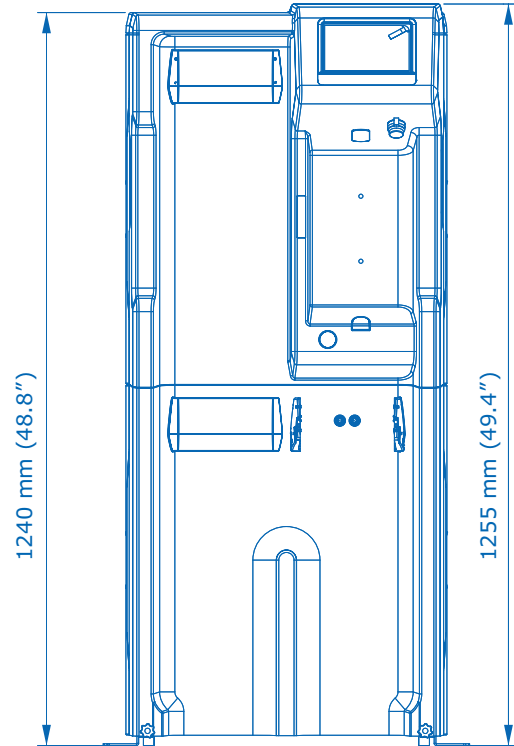

**Milli-Q®  
HR 7000 Series**

## Feed Water Requirements

Parameter	Value or Range
Pressure	2 - 6 bar
Flow rate	> 10 L/min at 2 bar
Feed water type	Potable water
Temperature	5 - 35 °C
Conductivity	10 - 2000 µS/cm at 25 °C
pH	4 - 10
Hardness (as CaCO <sub>3</sub> )	< 300 ppm
Silica concentration	< 30 ppm
Carbon dioxide concentration (CO <sub>2</sub> )	< 30 ppm
Langelier Saturation Index (LSI)	< 0.3
Fouling Index (FI <sub>2</sub> ) or Silt Density Index (SDI)	≤ 7(*)
Total Organic Carbon (TOC)	< 1 ppm
Free chlorine for Milli-Q® HR 7060 LC, 7120 LC, 7170, 7220 systems	< 1.5 ppm
Free chlorine for Milli-Q® HR 7060 HC, 7120 HC systems	< 1.5 ppm - 3 ppm

\* < 12 when the optional UF pretreatment is installed.

# Milli-Q® HR 7000 series

## Type 3 Water Purification Systems

### Milli-Q® HR 7000 Series Performances

Parameter	Value or Range
Conductivity	95% ionic rejection (99% particulates rejection)
Total Organic Carbon (TOC)	99% organic rejection for MW>200 Dalton

	Milli-Q® HR 7060	Milli-Q® HR 7120	Milli-Q® HR 7170	Milli-Q® HR 7220
Make-up flow rate to reservoir*	60 L/h 15.8 gal/h	120 L/h 31.7 gal/h	170 L/h 44.9 gal/h	220 L/h 58.1 gal/h

\* Nominal flow rates ±10% between 10 and 35 °C. Additional deratings of -3% per °C from 10°C to 5°C.

### Electrical Specifications

System Type	Voltage / Frequency	Power Consumption (VA)
Milli-Q® HR 7060/7120	220-240 VAC, 50/60 Hz	620
	120 VAC, 60 Hz	
	100 VAC, 50/60 Hz	
Milli-Q® HR 7170/7220	220-240 VAC, 50/60 Hz	750
	120 VAC, 60 Hz	
	100 VAC, 50/60 Hz	

### General Specifications

Noise level	< 50 dB at 1 meter
Communication protocol	TCP/IP/CGI, embedded web server and HTML 5 embedded website*
Communication ports	Ethernet, USB 2.0
Languages	English, French, Spanish, Portuguese, Italian, German, Russian, Chinese, Japanese

\* No additional software needed for remote control.

### Dimensions and Weights

	Milli-Q® HR 7060	Milli-Q® HR 7120	Milli-Q® HR 7170	Milli-Q® HR 7220
Dimensions (H x W x D) footprint	1 240 x 543 x 542 mm (48.8 x 21.4 x 21.3 in)			
Shipping weight	91 kg (207 lb)	94 kg (220 lb)	97 kg (233 lb)	103 kg (252 lb)
Dry weight	72 kg (166 lb)	75 kg (179 lb)	78 kg (192 lb)	84 kg (221 lb)

# SDS 500

## Storage, Protection & Distribution System

### SDS 500 Specifications

Tank volume	500 L (132 Gallons)
Usable water volume	400 L (105 Gallons), <i>an additional volume of 100 L is reserved for low and high level security</i>
Weight (filled with water)	660 kg (1455 lb)
Weight (empty)	Up to 140 kg (308 lb)
Dimensions H x W x D	2047 x 790 x 1082 mm (80.6 x 31.1 x 42.6 in)
Floor space required	0.85 m <sup>2</sup> (9.15 ft <sup>2</sup> )
Noise level	E.g. 45.5 dB @ 1m (BPR = 1.5b / flow rate 20 L/min) E.g. 54.7 dB @ 1m (BPR = 4b / flow rate 40 L/min)

### Pump Performances (Variable speed pumps)

Voltage / Frequency	Pump Performances
220-240 V, 50/60 Hz	Nominal: 16-40 LPM @ 1-4 bar
110-127 V, 50/60 Hz	4-9 GPM @ 14-58 psi
200 V, 50/60 Hz	Nominal: 16-40 LPM @ 1-3.5 bar*
100 V, 50/60 Hz	4-9 GPM @ 14-50 psi*

\* At 90V, performance is reduced to 16-40 LPM @ 1-3 bar (4-9 GPM @ 14-43 psi).

### Electrical Specifications

Voltage / Frequency	Maximum Power Consumption	Maximum Intensity
220-240 V, 50/60 Hz	2100 VA	< 9A
100-127 V, 50/60 Hz	2000 VA (120 V)	< 16A
	2000 VA (100 V)	< 20A

### Materials

Tank	Medium density polyethylene (MDPE)
Frame	Epoxy painted passivated steel
Valves and fittings	Polypropylene, polyamides, EPDM
Piping	Beta Polypropylene Homopolymer (Beta PP-H)
Pump wetted parts	316 SST and tungsten carbide / carbon and EPDM seals
BPR wetted parts	Polypropylene, EPDM, PTFE
Pressure gauge	Inox 316 L
Other mechanical parts	Polyethylene terephthalate (PETP)

### Plumbing Connections

Pure water inlet to tank	3/4" Sanitary TC
Tank drain	1 1/2" Sanitary TC
Tank loop inlet/return	1 1/2" Sanitary TC



# Storage Tanks and Accessories

## Storage with a Difference



### Guarantee the purity of your stored water

Pure water requires a storage system to prevent the degradation of your water quality. Merck Millipore's 30-, 60-, and 100-liter polyethylene (PE) storage tanks are designed to maintain consistent purity of stored water and provide effective protection against airborne contaminants.\*

### Prevent contamination

Water stagnancy can cause bacterial proliferation. Our optimal Automatic Sanitization Module (ASM) provides the ideal solution for the prevention of bacterial growth and biofilm formation on the inner surface of the storage tank. In addition, our advanced vent filter protects pure water from airborne contamination.

### Distribute your stored water where it is needed

To provide pure water for use with all of their applications, laboratories need to be able to distribute stored water from their water purification system storage tanks.

- For distribution of **non-pressurized pure water**, a valve is conveniently located on the front of the Merck Millipore storage tanks.
- For convenient **distribution of pressurized pure water** from the storage tank, an E-POD® point-of-delivery dispenser can be connected to an Elix® Advantage or Milli-Q® Integral water purification system.
- For **automatic feed** of pure water, distribution valves on the base of the storage tank allow connection to other laboratory equipment such as glassware washing machines. Distribution pumps are also available if needed.

*\* A complete line of storage tanks is available, ranging in capacity from a few liters to several hundred liters. Your nearest Merck Millipore office will be able to guide you in the choice of the tank best suited to your needs.*



# Optimized pure water storage

The main concern when storing pure water is degradation of water purity over time. Only a strict choice of storage tank materials, associated with a careful design and appropriate protection against airborne contaminants, can ensure consistent water quality during storage.

## Innovative storage tank design

Merck Millipore 30-, 60-, and 100-liter polyethylene storage tanks incorporate the latest technical developments and advanced features for stored water of consistent purity.

All tanks have a small footprint and are designed for wall-mounting if required. Underbench installation is also possible for some models.

### Unique features

- Polyethylene selected for its minimum release of extractables
- Opaque walls block sunlight to prevent algae development
- Smooth inner surface prevents biofilm formation
- Cylindrical shape minimizes surface area in contact with water
- Conical bottom allows complete draining for cleaning and rinsing
- Pure water smoothly fed in at the bottom of the tank prevents absorption of carbon dioxide
- Front valve enables manual dispense of pure water
- Distribution valves permit connection to other laboratory equipment
- Hermetically sealed lid blocks air from entering the tank
- Large top opening allows manual cleaning during sanitization procedure
- Compact space-saving design

### Fail-safe protection

- Sensor rod float switch system for automatic storage tank refill and indication of water level (% full)
- Overflow connected to the drain, in the unlikely event of a water system malfunction
- Direct display of stored water level on water purification system units
- Water sensor

## Storage tanks designed for efficiency

### Designed for efficiency

1. Hermetically sealed lid
2. Sensor rod float switch
3. Sanitary overflow
4. Blow-molded storage tank
5. Cylindrical shape
6. Conical bottom with distribution valves
7. Front dispensing valve
8. Advanced vent filter

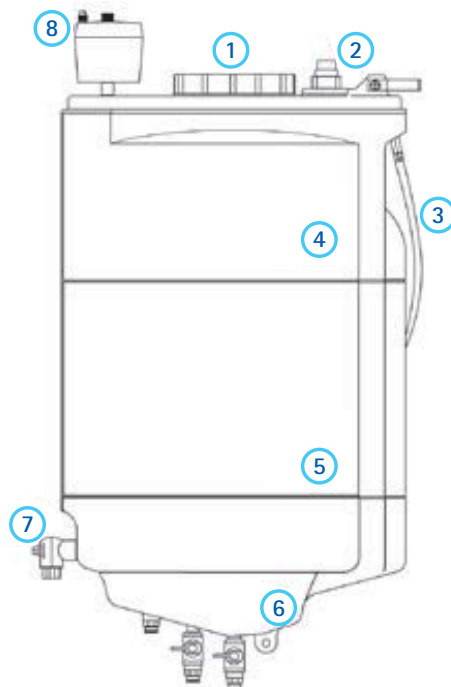

For details of the tests performed during the storage tank development process, please request the publication "R&D Notebook 1: Optimizing the storage of purified water for laboratory applications" (Ref. No.: RDO01EN00) from your local Merck Millipore representative.

# Storage Tank Accessories

In order to help ensure optimum purity and distribution of your stored water, Merck Millipore offers a range of accessories and connections for your storage tank, including the following items:

- Advanced Vent Filter
- Automatic Sanitization Module
- Air Gap Device
- E-POD® pure water remote dispenser
- Washer Distribution Kit
- Water Sensor
- Lab Close Kit

## Advanced vent filter: important protection against airborne contaminants

Air is contaminated by carbon dioxide, particles, microorganisms, and volatile organic compounds that come mainly from the laboratory atmosphere. To protect pure water from all these contaminants, Merck Millipore has developed an advanced storage tank vent filter that includes:

- Activated carbon to adsorb volatile organics (including lab solvents such as acetone, chloroform, and methanol)
- A soda-lime bed to remove CO<sub>2</sub>
- A Durapore® hydrophobic membrane for particle and bacteria retention

This advanced vent filter is recommended for the protection of high-resistivity water, such as Elix® product water, during storage. To protect RiOs™ reverse osmosis-quality water, a Durapore® 0.45 µm hydrophobic membrane vent filter is also available.

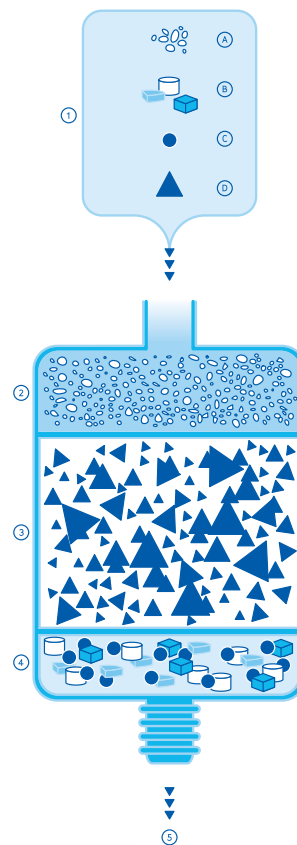

Advanced storage tank vent filter

1. Airborne Contaminants
  - A. Volatile Organics
  - B. Particles
  - C. Bacteria
  - D. CO<sub>2</sub>
2. Volatile Organics absorption
3. CO<sub>2</sub> removal
4. Particle and Bacterial retention
5. Storage tank inlet  
Purified air enters the storage tank



Complete Merck Millipore water purification chain with the ASM and water sensor

**Automatic Sanitization Module (ASM):**  
say "No!" to bacterial proliferation

Maintaining high purity water with low bacteria levels during storage is critical. If left to proliferate, trace levels of microorganisms present in pure water compromise water purity. This bacterial contamination is responsible for the formation of a biofilm – an accumulation of organic material made up of active and dead organisms, on the inner walls of the storage tank.

Even though chemical sanitization and mechanical scrubbing may be periodically performed, this biofilm is difficult to remove and is a frequent source of recontamination in stored water.

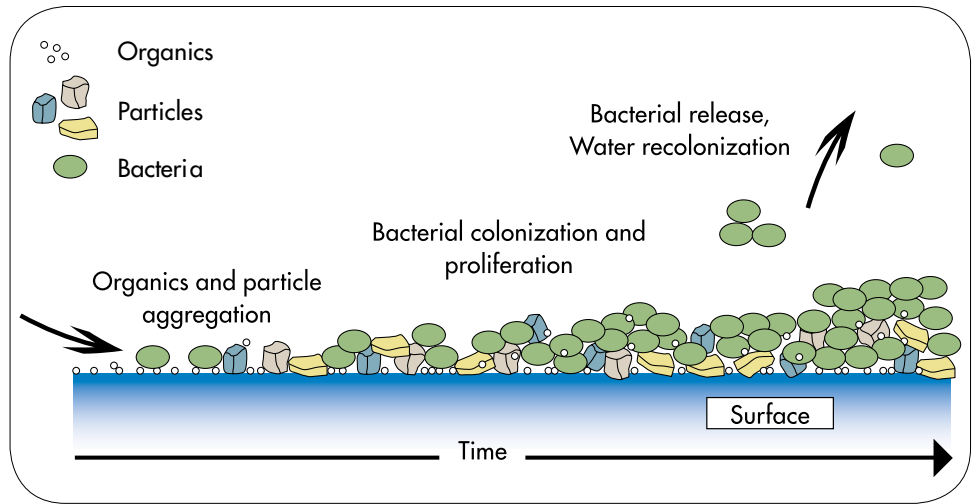

*Biofilm formation over time*

Merck Millipore's ASM is designed to prevent the growth and proliferation of bacteria and the resulting biofilm on the inner surface of Merck Millipore PE storage tanks. The ASM makes use of the germicidal properties of an ultraviolet (UV) light at 254 nm, which is fitted inside the tank.

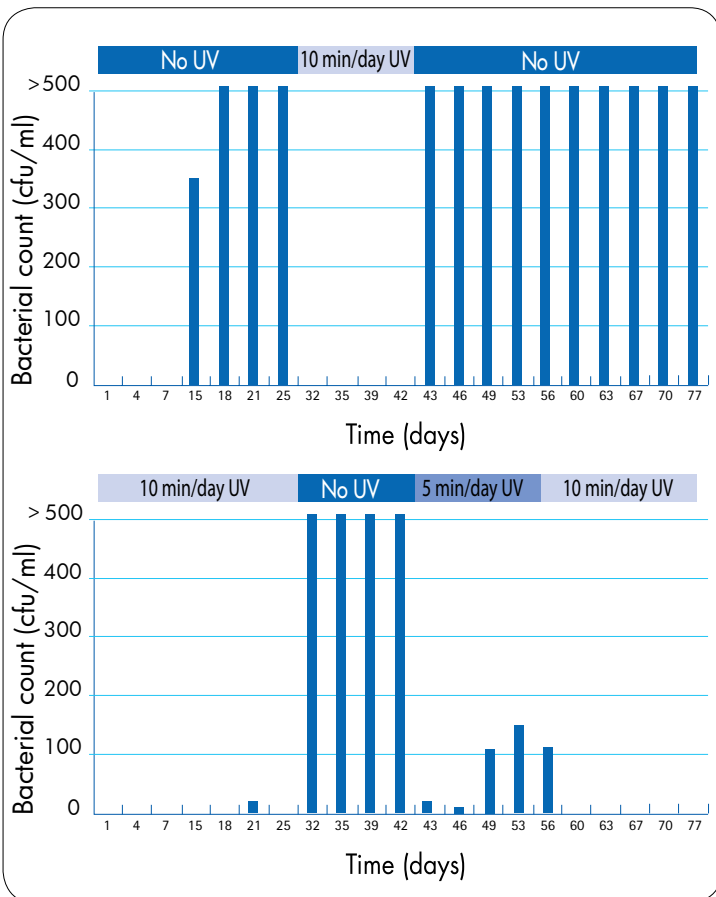

*Germicidal effectiveness of the UV lamp*

**The ASM provides full flexibility for guaranteed results**

- 254 nm UV lamp; selected for its germicidal effectiveness
- Pre-programmed intervals of 10-min / day automatic UV illumination for optimized efficiency
- Additional programmable and manual UV exposure possible to meet critical application requirements
- Up to 45 min /day of UV exposure for total flexibility
- Program daily time settings, UV cycles, and UV lamp operation displayed on the Millitrack® e-Solution dashboard
- UV lamp exchange alarm for easy maintenance
- Compact design allowing installation on top of the storage tank

**10 minutes of daily UV exposure is sufficient**

During development of the ASM, the UV lamp exposure cycles were optimized by examining the resulting bacterial reduction after exposure.

Two 60-liter storage tanks were fed by an intentionally contaminated reverse osmosis water purification system. The tanks were then emptied and refilled each day and alternately equipped with an ASM into which variable illumination times were programmed.

As shown in the graphs, 10 minutes per day of UV exposure were enough to make the tanks return to their original low bacterial levels.

### Air gap device for protection against bacteriological contamination

Water purification systems and storage tanks sometimes require a connection to the drain.

Drains are typically dirty environments contaminated by microorganisms, and in particular, bacteria. Therefore, when the outlet of the water system reject tubing is pushed into the drain, there is a risk that bacteria could contaminate the inside of the reject tubing, and then progressively move to the water system.

One way to prevent this from occurring is to install an air gap device on the reject tubing. This allows the reject water flow to move through the tubing without touching the inside of the contaminated drain environment. Installing an air gap device is an easy and safe way to prevent the development of bacteria above the air gap level.



*Air Gap Device*

### E-POD® pure water remote dispenser: pure water where you need it

The E-POD® Elix® water point-of-delivery unit can be connected to an Elix® Advantage pure water system or Milli-Q® Integral pure and ultrapure water system to dispense pure water wherever it is needed in the lab.

Advantages of the E-POD® remote dispenser include:

- Improved bacterial water quality (less than 0.1 cfu/mL, with final filter)
- Versatility enabling use for multiple applications or users when a Millipak® or Biopak® polisher is fitted to the dispenser outlet

- Volumetric dispensing to save time
- Ergonomic design and ease of use
- Flexibility, with installation of up to three E-POD® units per system
- Information at a glance thanks to the color backlit screen on the dispenser base
- Space-saving small footprint



*E-POD® pure water remote dispenser*



## Distribution pumps to meet increased demands

### Washer Distribution Kit

A key use of pure water is as feed to laboratory appliances such as glassware washers, autoclaves, sterilizers and weathering devices.

The Merck Millipore Washer Distribution Kit provides cost-effective and convenient distribution of pure water to common laboratory appliances, with flow rates between 12.5 – 13.5 L/min (at 2 bar or 30 psi, depending on voltage).

Installation of the small-footprint kit is fast, easy, and universal, with bench, underbench, or wall-mounted options. Users profit from a silent, automatic supply of pure water when required.

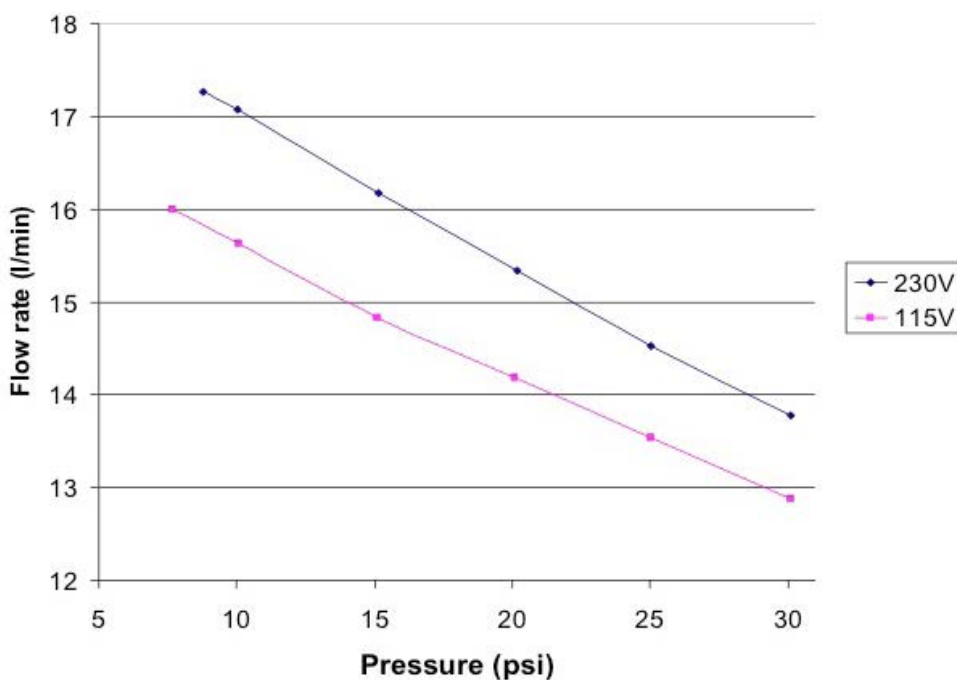

*The graph shows characteristics of Merck Millipore distribution pumps. Pumps provide a long service lifetime and quiet operation.*



Washer Distribution Kit

### Water sensor for control over feed water supply

If there is water on the floor, the water sensor enables shutdown of the feed water supply in order to prevent a lab flood.

### Lab Close Kit keeps your system in top condition when you're away

When your facility is closed for an extended time – such as vacation periods – the Lab Close Kit will avoid water purification system standstill during these long periods. The Lab Close Kit intelligently optimizes the consumption of water and electricity by your system, preventing the negative effects of nonuse, such as bacteria buildup. Your water purification system remains in top condition, ready for immediate use upon your return.

# Specifications & Ordering Information

## Specifications for Polyethylene Storage Tanks

There are several different storage tank sizes available in this range:

### 30-liter Storage Tank\*

Diameter	380 mm (14.82 in.)
Height	600 mm (23.4 in.)
Maximum Usable Capacity	25 L
Weight (full)	30 kg (66.14 lb)

### 60-liter Storage Tank

Diameter	380 mm (14.82 in.)
Height	840 mm (32.76 in.)
Maximum Usable Capacity	54 L
Weight (full)	59 kg (130.07 lb)

### 100-liter Storage Tank\*

Diameter	380 mm (14.82 in.)
Height	1255 mm (48.95 in.)
Maximum Usable Capacity	91 L
Weight (full)	98.5 kg (217.15 lb)

\* For 30-liter and 100-liter storage tanks, underbench models are also available.

## Ordering Information

Description	Catalogue No.
<b>Polyethylene Storage Tanks</b>	
30-liter PE tank	TANKPE030
30-liter PE underbench tank	TANKBI030
60-liter PE tank	TANKPE060
100-liter PE tank	TANKPE100
100-liter PE underbench tank	ZBITANK01

Description	Catalogue No.
-------------	---------------

## Accessories

### Advanced Vent Filter

Advanced vent filter (for Elix® water purification systems)	TANKMPK01
Standard vent filter (for RiOs™ water purification systems)	TANKMPK02

### Automatic Sanitization Module

Milli-Q® Integral; Milli-Q® Direct, Elix® Advantage, and Elix® Reference water purification systems	TANKASMIN
ASM for RiOs™ / Elix® / AFS® Essential water purification systems	TANKASMES

### Air Gap Device

Air Gap Device	AIRGAP001
----------------	-----------

### E-POD® Pure Water Remote Dispenser

E-POD® pure water dispenser	ZRXSP0D01
-----------------------------	-----------

### Washer Distribution Kit

Washer Distribution Kit (Left) 230 V	ZWDK5L100
Washer Distribution Kit (Left) 115 V	ZWDK6L100
Washer Distribution Kit (Right) 230 V	ZWDK5R100
Washer Distribution Kit (Right) 115 V	ZWDK6R100

### Water Sensor

Connection from the system	ZFWATDET4
Connection from the tap water source	ZFWATDET1 (120 V) or ZFWATDET2 (230 V)
Water sensor with cable	TANKLK002

### Lab Close Kit

Milli-Q® Integral; Elix® Advantage; Elix® Reference; and Milli-Q® Direct water purification systems	LABCLOSE1
RiOs™ / Elix® / AFS® Essential water purification systems	Included, setting to be activated



# WolfLabs

**Pricing on any accessories shown can be found by keying the part number into the search box on our website.**

The specifications listed in this brochure are subject to change by the manufacturer and therefore cannot be guaranteed to be correct. If there are aspects of the specification that must be guaranteed, please provide these to our sales team so that details can be confirmed.

**[www.wolflabs.co.uk](http://www.wolflabs.co.uk)**

**Tel : 01759 301142**

**Fax : 01759 301143**

**[sales@wolflabs.co.uk](mailto:sales@wolflabs.co.uk)**

Please contact us if this literature doesn't answer all your questions.